

DESIGNER LINE PASS THRU FREEZER (0°)

Model: D2RFENPT

Natural Refrigerant R-290 Model

2-Section Dual Temp Extra-Wide Pass-Thru Refrigerator/Freezer (0°F)

D2RFENPT - Stainless steel front, aluminum end panels and interior

D2RFENSAPT - Stainless steel exterior, aluminum interior

D2RFENSSPT - Stainless steel exterior and interior



Options and Accessories

(upcharge and lead times may apply)

Additional epoxy coated steel shelves	Increased refrigeration systems
Chrome or stainless steel shelves	Special electrical req. (consult factory)
Pan slide assemblies	Correctional Facility Options
Rehinging of doors (consult factory)	• One way security screws
Wine rack (refrigerator section)	• Locking hasp (lock not included)
Casters	• Stainless steel mesh cover
Custom laminates	• Coverless hinges
Half doors	

Consult factory for other model configurations, options and accessories.



Toll-Free: 800-523-7138
Phone: 215-244-1400
Fax: 215-244-9579

539 Dunksferry Road
Bensalem, PA 19020
www.continentalrefrigerator.com

Project Name:

Model Specified:

Location:

Item No:

Quantity:

AIA #:

SIS #:

Standard Model Features

REFRIGERATION SYSTEM

Separate, self contained, performance rated "plug" refrigeration systems

Natural, environmentally safe, high efficiency R-290 refrigerant¹

Refrigeration system is readily accessible on top of cabinet, separate from the "food zone"

Automatic, hot gas condensate evaporator

Expansion valve system

CABINET ARCHITECTURE

3" non-CFC polyurethane foam insulation

Smooth, polished chrome workflow door handles

Cam action, lift off hinges

Self-closing doors

Magnetic snap in Santoprene™ door gaskets

Cylinder lock in each door

Heavy duty, epoxy coated steel shelves

Heavy duty pilaster strips

6" adjustable stainless steel legs

MODEL FEATURES

LED interior lighting

Electronic controllers with digital display & hi-low alarm

Top and side air distribution ducts

Cabinet upper side panels and refrigeration "plug" system can be removed and reinstalled at job site

Off-cycle defrost (refrigerator section)

Automatic electric defrost (freezer section)

APPROVAL:

Model Specifications

DIMENSIONAL DATA

Net Capacity (cubic feet)	22 (623 cu l)
Width, Overall (inches)	28 1/2 (724 mm)
Depth, Overall (inches) (including handles)	38 3/4 (984 mm)
Depth (inches) (less doors)	32 (813 mm)
Depth (inches) (doors open 90°)	84 (2134 mm)
Clear Door Width (inches)	21 7/8 (556 mm)
Clear Door Height (inches)	58 5/8 (1489 mm)
Height, Overall (inches) (including 5" casters)	83 1/4 (2089 mm)
Number of Doors	4
Number of Shelves	6
Shelf Area (square feet)	20.4 (1.9 sq m)
Tray Slide Capacity	24

REFRIGERANT DATA

Condensing Unit Size (H.P.)	1/4, 1/2
Capacity (BTU per hour)*	1940, 1590

ELECTRICAL DATA

Voltage (International)	115/60/1 (220/50/1)
Feed Wires (including ground)	3
Total Amps (International)	5.5 (3.9), 6.9 (4.2)
Defrost Amps (International)	4.3 (2.2)
10 ft. Cord/Plug [attached] (International)	Yes (No)

SHIPPING DATA

Height - Crated (inches)	85 1/2 (2172 mm)
Width - Crated (inches)	31 5/8 (803 mm)
Depth - Crated (inches)	42 (1067 mm)
Volume - Crated (cubic feet)	65 (1841 cu l)
Weight Std - Crated (pounds)	375 (170 kg)
Weight SS - Crated (pounds)	435 (197 kg)

* Rating @ +25°F evaporator, 90°F ambient (refrigerator)

* Rating @ -15°F evaporator, 90°F ambient (freezer)

Figures in parentheses reflect metric equivalents rounded to the nearest whole unit.



Equipped with one NEMA-5-15P Plug
(varies by country)

Model Plan Views

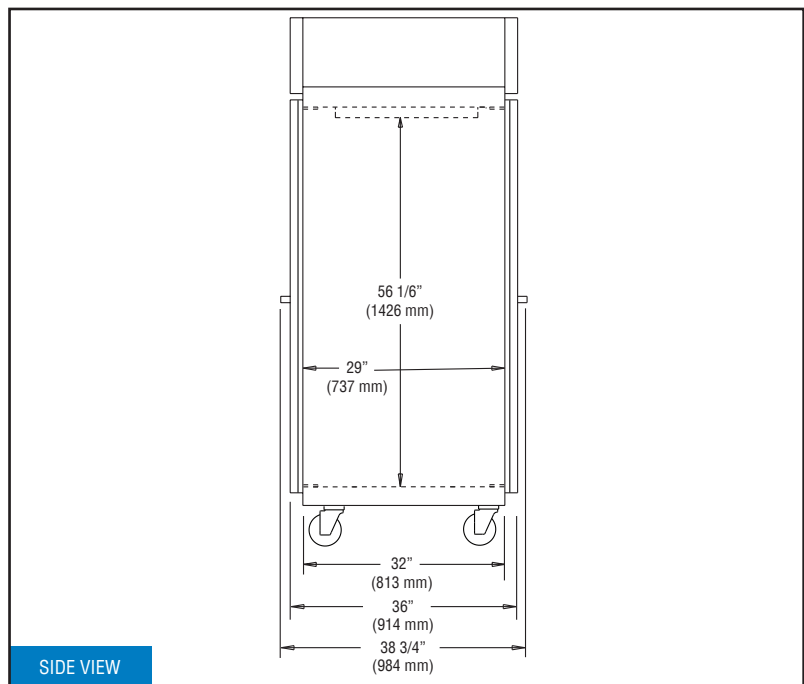
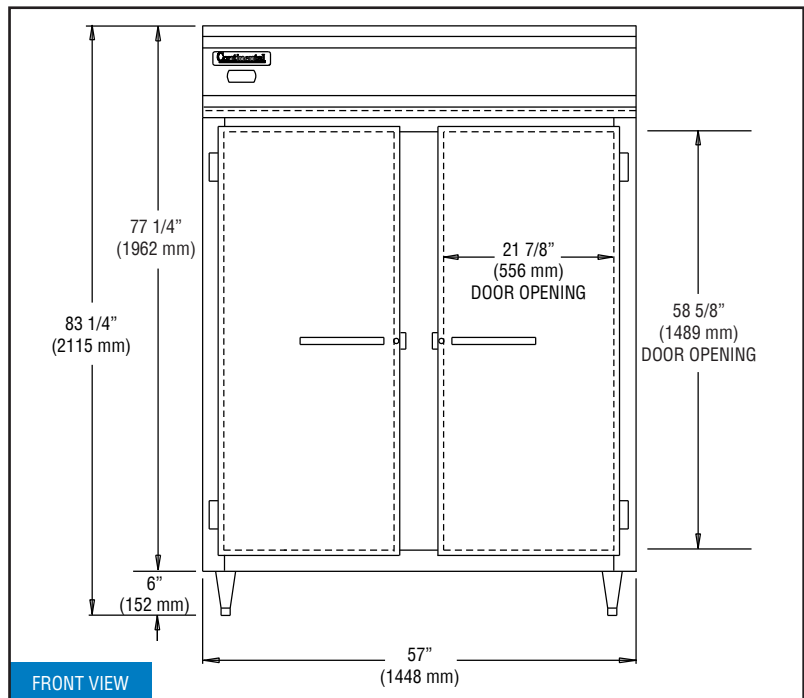

Continental
Refrigerator

Toll-Free: 800-523-7138
Phone: 215-244-1400
Fax: 215-244-9579

539 Dunksferry Road
Bensalem, PA 19020
www.continentalrefrigerator.com

Due to our continued efforts in developing innovative products, specifications subject to change without notice.

